

## Application

The Tek-ENTRY<sup>®</sup> Apartment Entry Intercoms provide two-way communications between the building entrance and each suite. Hands-free loudspeaker operation at the entrance/lobby panel and push button controlled communication at the suite/apartment locations provide for easy operation. Controlled door entry is permitted by push button operation at the suite in conjunction with electric door release.

Optional equipment is available to provide additional functionality, such as post office key door release, additional entrance panels, strobe light call indication (LI404B) and auxiliary relay (RY014B) for ancillary device operation (bells, lights, etc.).

## Procedure

1. Read installation instructions to determine equipment location and installation methods.
2. Install housings (or back boxes) and wiring.
3. Check wiring, connect and install equipment.
4. Apply power and check operation.

## Equipment Location

### *Suite/Apartment Stations*

Locate suite stations (also known as remote stations) where convenient for use. Install a housing or back box at the desired location.

### *Entrance/Lobby Panel*

Use an OH190 series housing and OF190 series frame for flush wall mounting. Use an OF190S series frame for surface mounting. Locate the entrance panel where it is sheltered from weather.

### *PK543A Amplifier*

Install the amplifier inside the entrance panel when using an OH190 series housing. The amplifier must be installed outside the entrance panel when using an OF190S series surface frame. Refer to *Connections section, item #3, on page 2* for further details.

## Wiring

### *Suite/Apartment Stations*

Stations may be connected in risers using the following cable configurations:

3-wire stations: 1 twisted pair #22 AWG, plus 1 conductor #22 AWG per station in riser.

4-wire stations: 1 twisted pair #22 AWG, plus 1 conductor #22AWG, plus 1 conductor #22 AWG per station in riser.

5-wire stations: 1 twisted pair #22 AWG, plus 2 conductor #22 AWG, plus 1 conductor #22 AWG per station in riser.

The maximum cable length is 400 feet (120 meters). Additional risers may be added as needed. Station cables must not be run in the same conduit with (or too close to) electrical wiring or background music, and must not be close to fluorescent lighting or other electrical equipment. Failing to observe this requirement can result in noise entering the intercom audio. Ensure that sufficient amounts of cable are left in the back box to make connections to stations.

### *Transformer*

Cable wiring must be 2 conductor #18 AWG with a maximum cable length of 80 feet (25 meters). If using #14 AWG wire, this distance can be extended to 200 feet (60 meters). Route cable away from suite station wiring and maintain a minimum of 3 feet (1 meter) of clearance between the transformer and the amplifier.

### *Door Release*

Cable wiring must be 2 conductor #18 AWG with a maximum length of 50 feet (15 meters). See *Figure 2 on page 5* for specifics of each door control unit configuration. **Note: An SS106 transformer must be used for 24 VAC doorstrike and 12 VDC Maglock applications (8 volt tap required).**

## Connections

Before connecting to unit and applying power, verify that wires are free from shorts and grounds. Make connections as per *Figure 1 on page 4*. Observe the following notes:

1. Do not apply power to the transformer primary until the entire system has been installed and checked for shorts and grounds. The common wires connecting to terminals 1, 2, 3, E and 5 must show open circuit when tested with an ohmmeter.
2. Use twisted pair wiring as shown. *Do not* interchange wires or reverse polarity.
3. Install PK543A amplifier inside the entrance panel when using OH190 series housing. If it is necessary to install the amplifier elsewhere due to temperature extremes (operating temperature range is 0–30°C) or because the entrance panel is not large enough to house the amplifier, then use a 2 conductor shielded cable for the entrance panel speaker (connect shield drain to amplifier terminal G).
4. The amplifier must be located at least 3 feet (1 meter) from the transformer or other electrical devices.
5. *Do not* run wiring for station common wires and entrance panel speaker in the same cable and/or conduit. This will cause feedback on the system.
6. Door release wiring should be run separate from entrance panel speaker wiring.

## Shunt and Dipswitch Settings

Set the dipswitches on the PK543A as per application requirements. See also *Figure 4 on page 7*. The selectable features and controls are as follows:

- Shunt JP5** Install for maglock applications. Maximum current for maglock is 500 mA at 12 VDC, or 250 mA at 24 VDC.
- Shunt J2** Place shunt across: 1–2 for doorstrike applications; 2–3 for maglock applications
- Shunt J1** Place shunt across: 1–2 for +12 VDC maglock; 2–3 for +24 VDC maglock or AC/DC doorstrike applications
- Short Door Time** Set SW1 to ON (right) and SW2 to OFF (left), 2 seconds
- Medium Door Time** Set SW1 to OFF (left) and SW2 to ON (right), 10 seconds
- Long Door Time** Set SW1 to OFF (left) and SW2 to OFF (left), 25 seconds
- Entrance Tone** Set SW3 to ON (right) to activate this feature—must use warble tone

**Postal Timer** Set SW4 to ON (right) and SW5 to OFF (left) to make postal control timer independent at 25 seconds

**PK543 Compatible** Set SW4 to OFF (left) and SW5 to ON (right) for PK543 drop-in replacement\*

**Door Hold Time Out** Set SW6 to OFF (left) to activate this feature

**Talk Interlock** Set SW7 to OFF (left) to activate this feature (available for 4-wire stations only)

\* For PK543 Compatible mode, set SW4 OFF, SW5 ON, SW6 ON & SW7 ON. Also remove JP5 shunt, set J2 to shunt 1–2 and set J1 shunt to 2–3.

The Entrance Tone setting, when active, will generate a user feedback tone at the entrance panel when users press call buttons. If the warble tone is in use and the entrance tone feature is active, the tone will also be heard through the entrance panel speaker when the call button is pressed.

The Door Hold Time Out setting, when active, will allow the door control device (doorstrike, maglock, etc.) to time out normally, despite the **DOOR** button being held at the suite.

**Safety Tip:** The Talk Interlock setting, when active, will require that the **TALK** button (at the suite) is pressed before the **DOOR** button will activate the door control device.

## Optional Accessories

Install optional accessories according to the instructions provided.

## Finish & Test Installation

1. Confirm that all equipment is properly installed.
2. Connect power to transformer primary (120 VAC), and ensure that local electrical codes have been complied with.
3. At the entrance panel, push each button and verify that the correct suite is called.
4. At each suite, push the **TALK** and **LISTEN** buttons to communicate with a person at the entrance panel. Then push the **DOOR** button to confirm that the door release operates correctly.

## Adjustments

**Voice Volume** and **Tone Volume** can be adjusted on the amplifier, via the access hole, with a small screwdriver.

## Troubleshooting

(Refer to *Figure 5 on page 8* for additional information.)

### **Entire System Dead**

If power LED is not illuminated, check for 16 VAC at transformer secondary and 120 VAC at transformer primary. If LED is illuminated, review field wiring and perform direct test using one of the apartment stations to eliminate field wiring.

### **No Talk**

Check wiring to terminals 1 and 2, and check whether wiring to entrance panel speaker is shorted or open. Suite station can be swap tested with another working unit.

### **No Listen**

Check wiring to terminals 1 and 3, or for short between terminals 1 and 2. Check to see if wiring to entrance panel speaker is shorted or open. Suite station can be swap tested with another working unit.

### **No Door Operation**

Check wiring to door release for shorts and opens, or for defective door release. Confirm that shunts are properly set for door release type and that connections to appropriate output have been made. Check wiring to terminals 2 and 3, or 1 and E (depending upon suite station type).

### **No Call Tone**

Check wiring to terminal Z or ZW to entrance panel, related entrance panel call buttons, and suite station X terminal. Suite station can be swap tested with another working unit.

### **Excessive Hum or Distortion**

Check whether wiring is installed too close to electrical wiring or electrical devices; amplifier installed too close to transformers or other electrical devices; twisted pair wiring not used as required; or amplifier voice volume set too high.

### **Radio Interference**

Connect G terminal from amplifier to electrical ground.

**Note: This connection is not shown on the wiring diagram, since the situation is not always improved by adding it.** If the problem persists, consult the factory or service representative.

### **Oscillation(feedback or howling)**

Reduce the voice volume until oscillation is eliminated. If oscillation stops when the call tone wire is removed from ZW, set entrance tone (SW3) to the OFF (left) position.

## Signal Flow and Theory of Operation for PK543A Amplifier and Apartment Intercom System

The following example describes an apartment intercom system using a PK543A in conjunction with a 4-wire suite station. Refer also to *Figure 5 on page 8*.

### **Call Button**

Pressing a suite station call button on the entrance panel routes the call tone from the Z or ZW terminal on the PK543A to the X terminal (tone in) on the associated suite station. This signal then passes through the speaker and returns to the PK543A via the 1 terminal (audio common). If the warble tone is in use and the entrance tone feature is active, the tone will also be heard through the entrance panel speaker when the call button is pressed.

### **Talk Button**

Pressing the **TALK** button at a suite station connects the suite station's internal speaker to terminals 1 and 2 of the PK543A, which serves as an audio input to the amplifier. The audio is then amplified and sent to terminals A and G, which are connected to the entrance panel's speaker (speaker mode).

### **Listen Button**

Pressing the **LISTEN** button at a suite station connects the suite station's internal speaker to terminals 1 and 3 of the PK543A, which serves as an audio output from the amplifier. This allows the suite station to receive the amplified audio being received by the amplifier on terminals A and G from the entrance panel speaker (microphone mode).

### **Door Button**

Pressing the **DOOR** button at a suite station creates a closure between terminals 2 and 3 on the PK543A. This state is sensed by the amplifier and causes the door release to be activated (output specifics are based on PK543A settings). This state is also triggered by shorting terminals 1 and E as is typically done by a postal lock.

**Figure 1—PK543A Wiring Diagram**

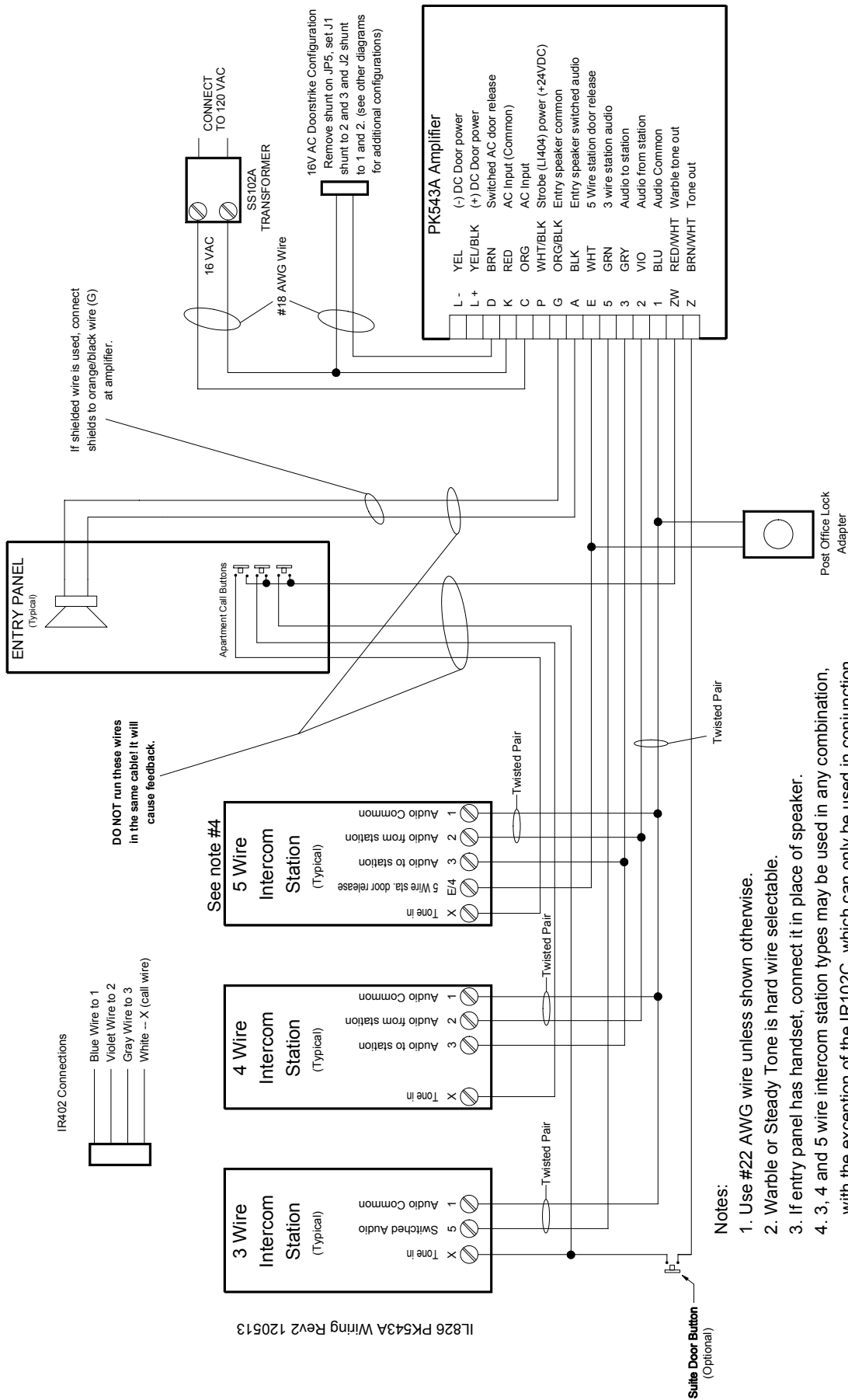

**Notes:**

1. Use #22 AWG wire unless shown otherwise.
2. Warble or Steady Tone is hard wire selectable.
3. If entry panel has handset, connect it in place of speaker.
4. 3, 4 and 5 wire intercom station types may be used in any combination, with the exception of the IR102C, which can only be used in conjunction with other IR102B or C devices.
5. Door release wiring should be run separate from entrance panel speaker wiring.
6. Shunts referred to in diagrams are located on PK543A.
7. Terminal P is for strobe only, do NOT connect other wires to this terminal.

## Figure 2—PK543A Doorstrike Applications

**+24V AC Doorstrike Application:**  
 Remove JP5 Shunt  
 Set J1 shunt to 2 and 3  
 Set J2 shunt to 1 and 2

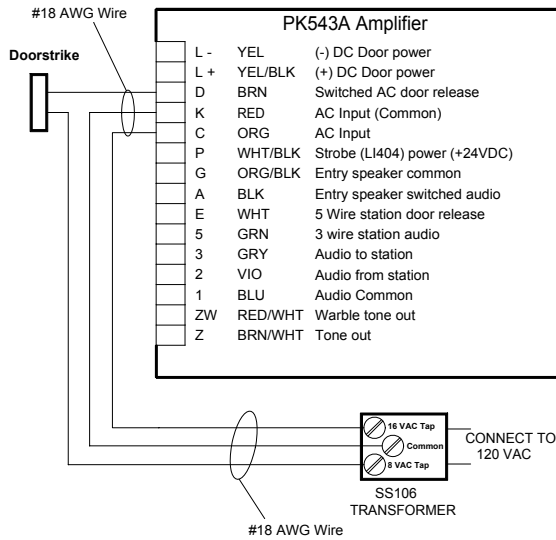

**16V DC Doorstrike Application:**  
 Remove JP5 Shunt  
 Set J1 shunt to 2 and 3  
 Set J2 shunt to 1 and 2

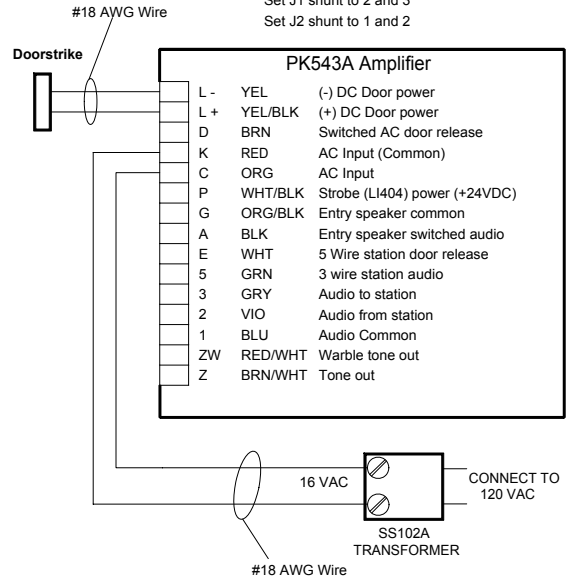

IL826 PK543A Doorstrike Applications 1 Rev0 050604 1

**+12VDC/500mA DC Maglock Application:**  
 Install JP5 Shunt  
 Set J1 shunt to 1 and 2  
 Set J2 shunt to 2 and 3

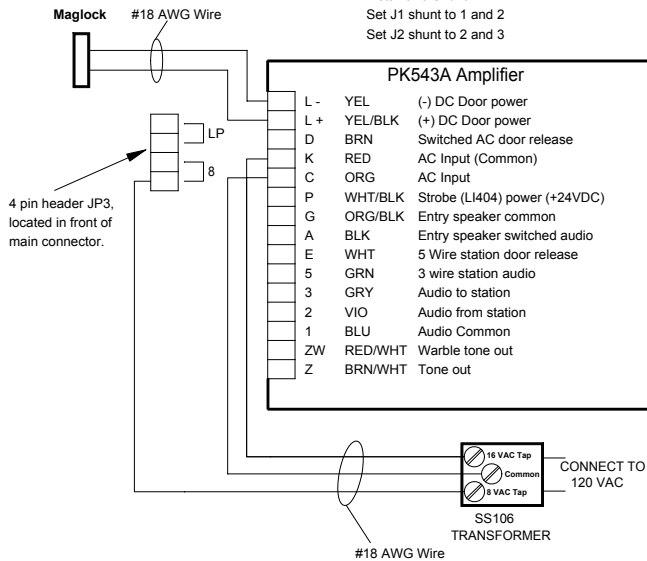

Note: LP and 8 are each available on two pins of the JP3 connector. Brackets are provided to identify.

**+24VDC/250mA DC Maglock Application:**  
 Install JP5 Shunt  
 Set J1 shunt to 2 and 3  
 Set J2 shunt to 2 and 3

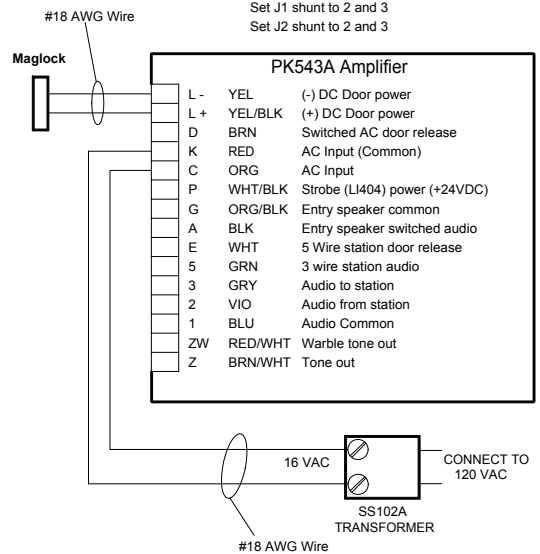

IL826 PK543A Doorstrike Applications 2 Rev2 102008 1

**Figure 3—PK543A LED Applications**

**LED power from External Source**

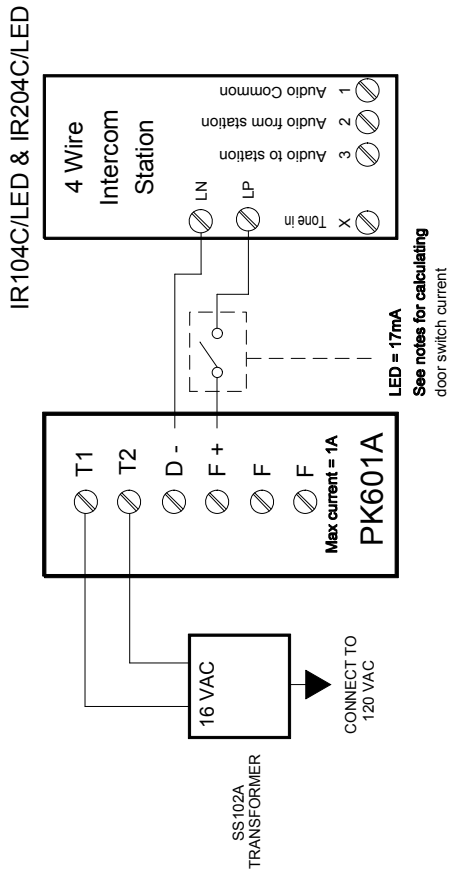

**LED Power Calculations for Door Switch:**

Each apartment station with a door indicator LED will draw 17mA when the door switch closes (caused by the actual building door being opened). The PK543A can supply a maximum of 20 apartment stations. If an external power supply is used then the overall number of apartment stations can be multiplied by 17mA (milliamps) to determine power supply load and switch maximum current rating.

**LED power from PK543A (Max 20 stations)**

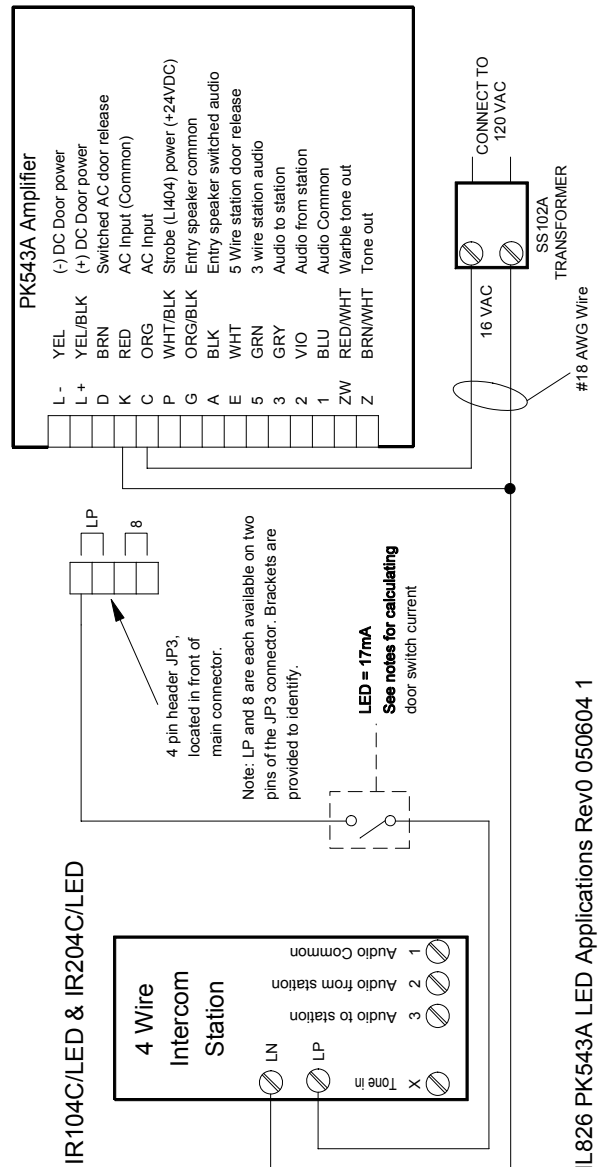

IL826 PK543A LED Applications Rev0 050604 1

**Figure 4—PK543A Shunts and Settings**

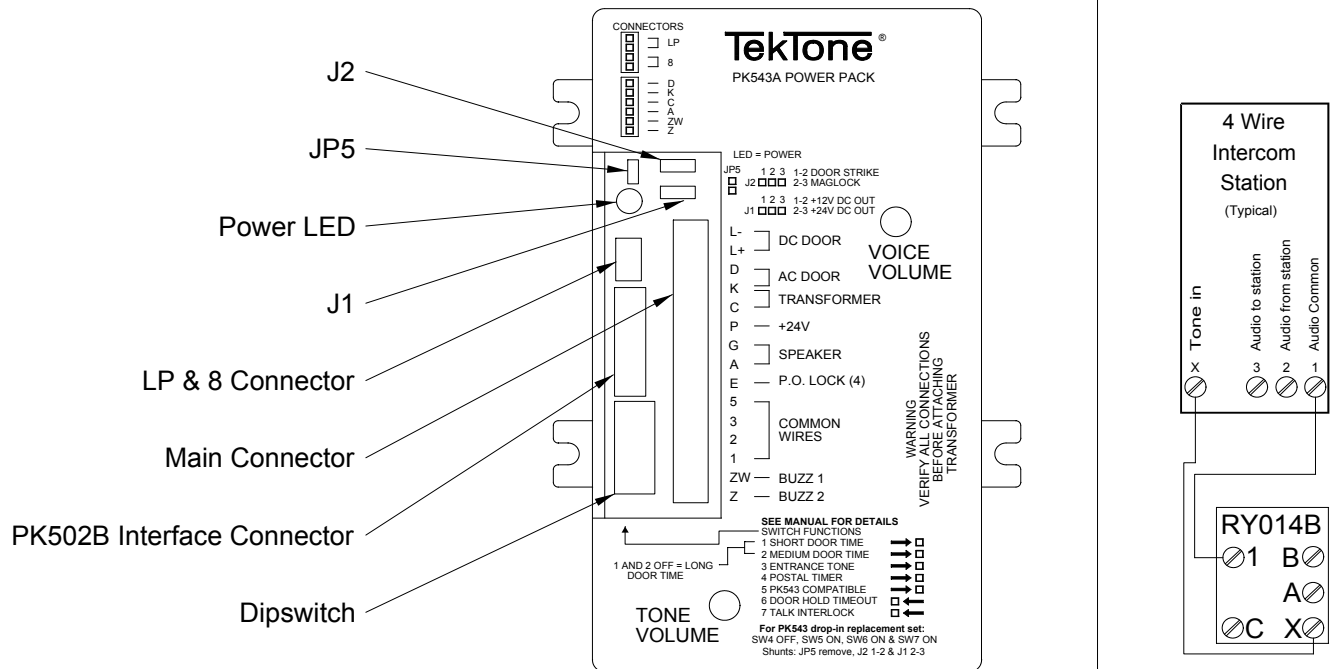

**Dipswitch Settings:** (right and left are referenced from the view above)

Short Door Time - set SW1 to ON (right) and SW2 to OFF (left), 2 seconds

Medium Door Time - set SW1 to OFF (left) and SW2 to ON (right), 10 seconds

Long Door Time - set SW1 to OFF (left) and SW2 to OFF (left), 25 seconds

Entrance Tone - set SW3 to ON (right) to activate this feature

Postal Timer - set SW4 to ON (right) and SW5 to OFF (left) to make postal control timer independent at 25 seconds

PK543 Compatible\* - set SW4 to OFF (left) and SW5 to ON (right) to make unit for drop-in replacement for PK543

Door Hold Time Out - set SW6 to OFF (left) to activate this feature

Talk Interlock - set SW7 to OFF (left) to activate this feature (available for 4-wire stations only)

\* - For PK543 Compatible mode, set SW4 OFF, SW5 ON, SW6 ON & SW7 ON.  
Also remove JP5 shunt, set J2 to shunt 1 - 2 and set J1 shunt to 2 - 3.

Figure 5—Theory Diagram

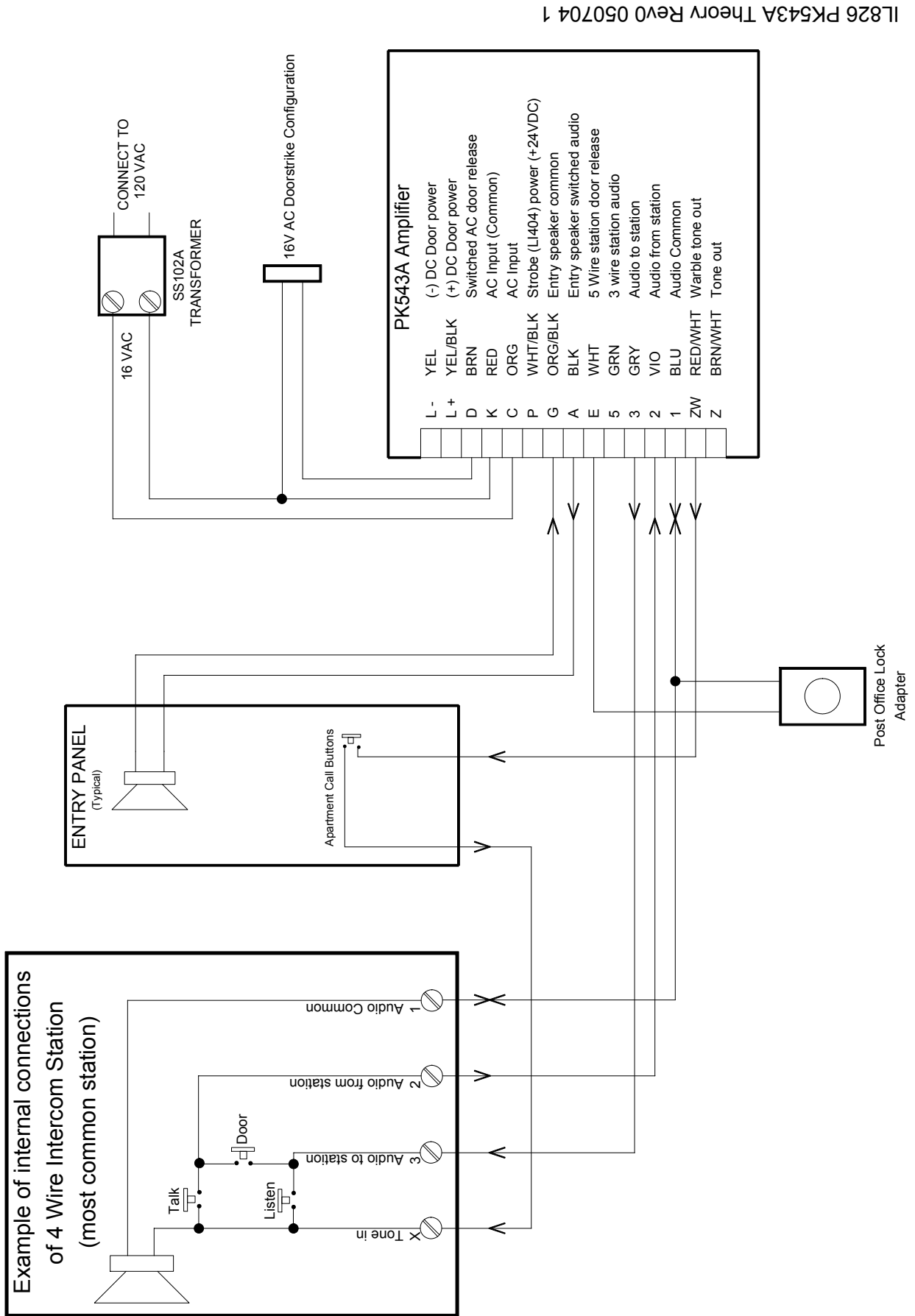

IL826 PK543A Theory Rev0 050704 1