

Tek-CARE® NC300™ II System Connection Diagram

This Block Wiring Diagram is a subset of IL715 Rev. 20 – 04/2016, and is provided for quotation purposes only. Refer to the manual for complete wiring and installation instructions.

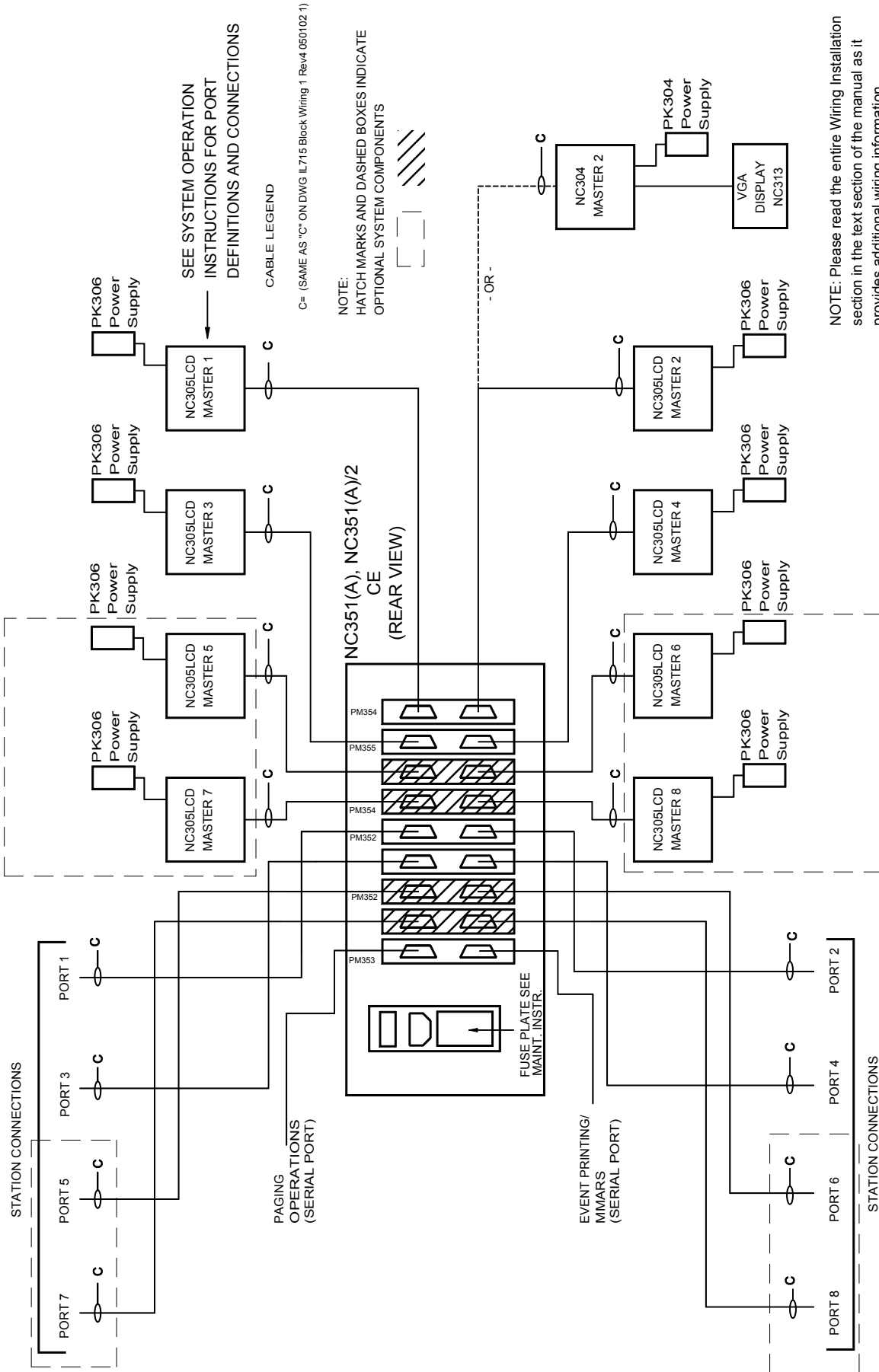



NC304, NC305LCD, NC306 Block Wiring Diagram

This Block Wiring Diagram is a subset of IL715 Rev. 20 – 04/2016, and is provided for quotation purposes only. Refer to the manual for complete wiring and installation instructions.

